



### Variangle bevel cutterhead

**Application:**

For different bevels or straight jointed edges and panel raising. Large swivelling range up to 85°.

**Machine:**

Spindle moulders, moulders, edgbanding machines and double-end tenoners.

**Workpiece material:**

Softwood and hardwood, uncoated, coated and veneered chipboard and fibre materials, glulam.

**Technical information:**

Knife holder swivel. Accurate, easy readable angle scale for precise adjustment to required bevel angle.



**Adjustable bevel angle**

WW 341 1

D	D <sub>max</sub>	SB	BO	BO	BO <sub>max</sub>	Swivel range	n	Z	ID
mm	mm	mm	mm	in	mm	°	min <sup>-1</sup>		
150	174	50	30		40	0 - 85	5000 - 8000	2	024275 ●
150	174	50	31.75	1 1/4"	40	0 - 85	5000 - 8000	2	024281
150	174	50	40		40	0 - 85	5000 - 8000	2	024288
170	194	50	50		60	0 - 85	4500 - 6000	2	024278 ●

**Spare knives:**

Part-no.	BEZ	ABM	QAL	VE	ID
		mm		PCS	
1	Turnblade knife	50x12x1.5	HW-05F	10	005086 ●

**Spare parts:**

Part-no.	BEZ	ABM	ID
		mm	
2	Clamping wedge with pin	48x10.88x6	005346 ●
3	Allen screw	M6x12	006035 ●
3	Allen screw	M6x16	006036 ●
	Allen key	SW 8, L 100	005437 ●
	Allen key	SW 3	005433 ●
	Setting gauge for knives	80x12x9.5	005352 ●

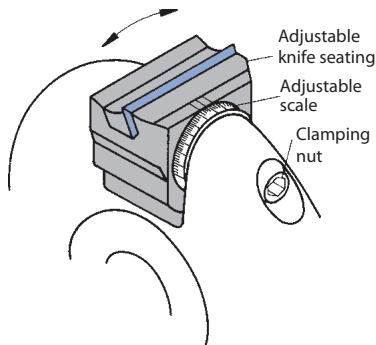

Bevel cutterhead with swivelling knife holder

